

SHEET REVISION STATUS					
5	4	3	2	1	SHEET NO
					LATEST REV

REVISIONS				
REV.	ECO	DESCRIPTION	DATE	APPROVED

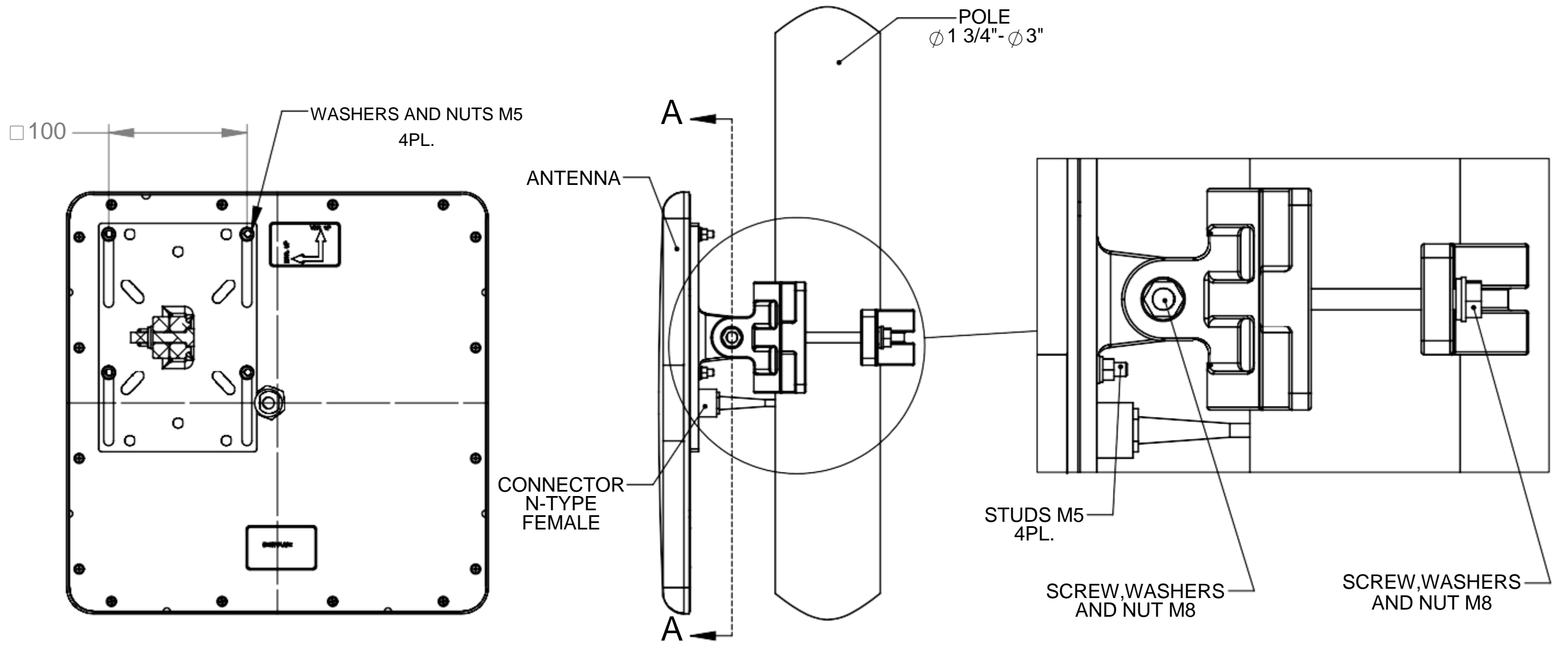

**SECTION A-A**

UNLESS OTHERWISE SPECIFIED DIMENSIONS ARE IN mm PER ANSI Y14.5M-1982		CONTRACT TO		<b>ARCADIAN</b>	
TOLERANCE		DWG	Yael		
LINEAR	ANGULAR	CHKD			
$\pm 0.2$	$\pm / \circ$	DSGN	ILAN V.	I.V	31.7.19
 SURFACE TEXTURE IN MICRO IN.		PROJ			
		MFG			
		SIZE	DWG NO		RD44507800C
		A3			
		SCALE- 1:3			SHEET 1 OF 3

8 7 6 5 4 3 2 1

D

D

C

C

B

B

A

A

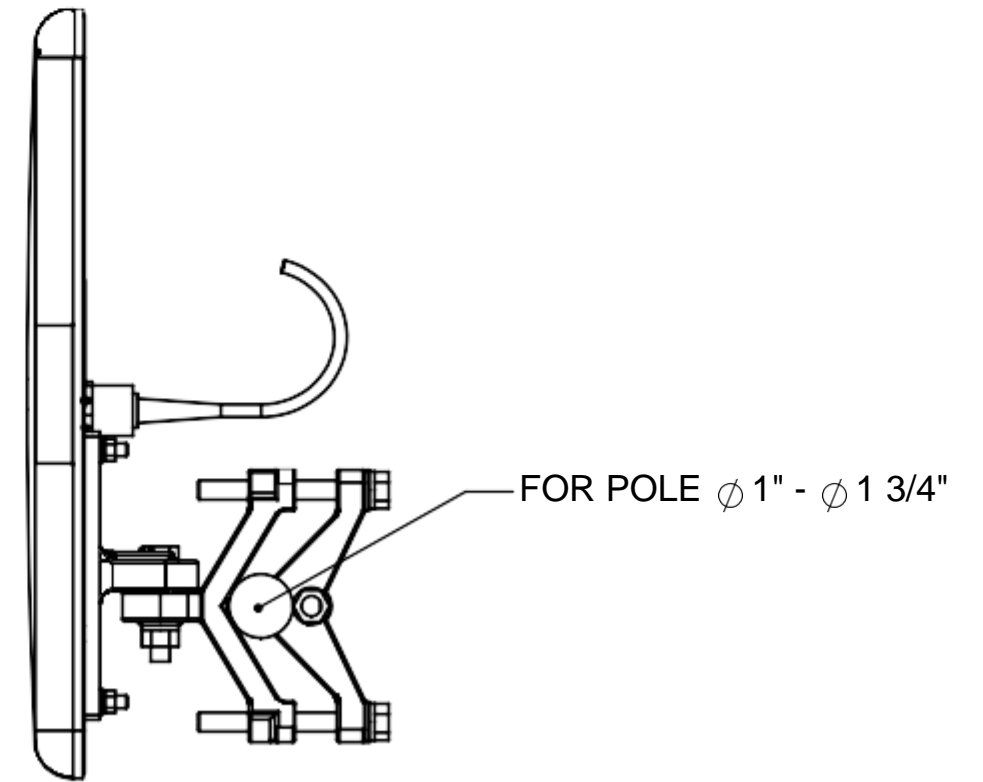
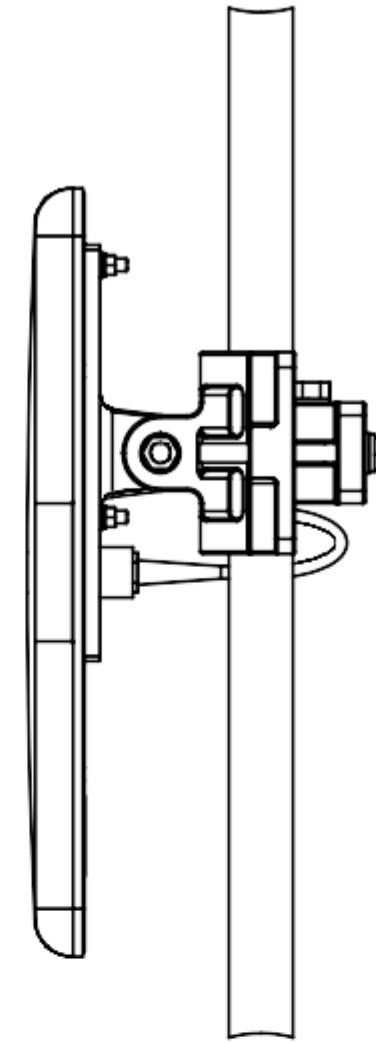
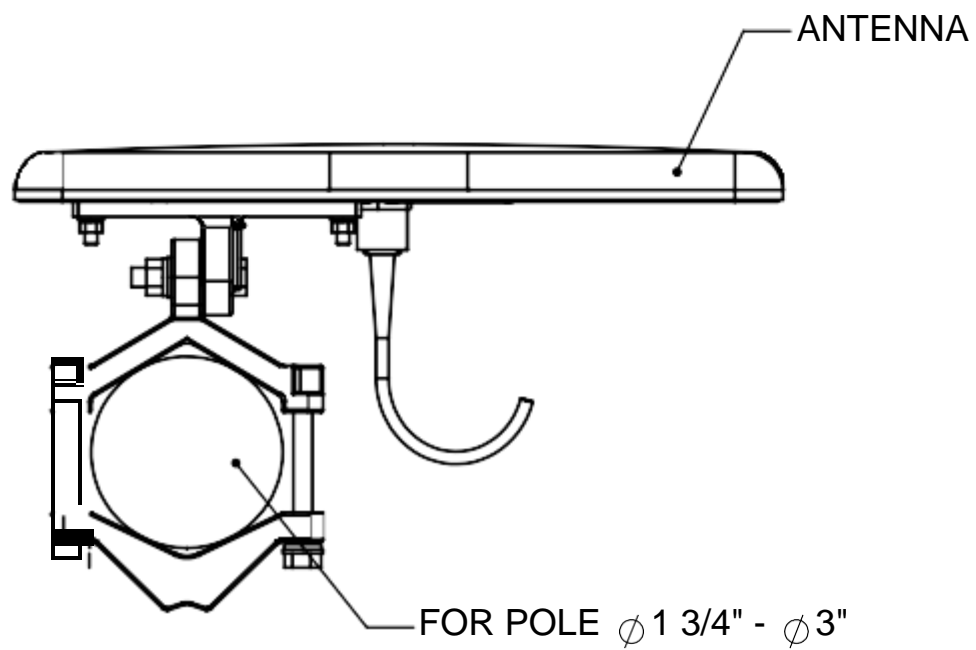
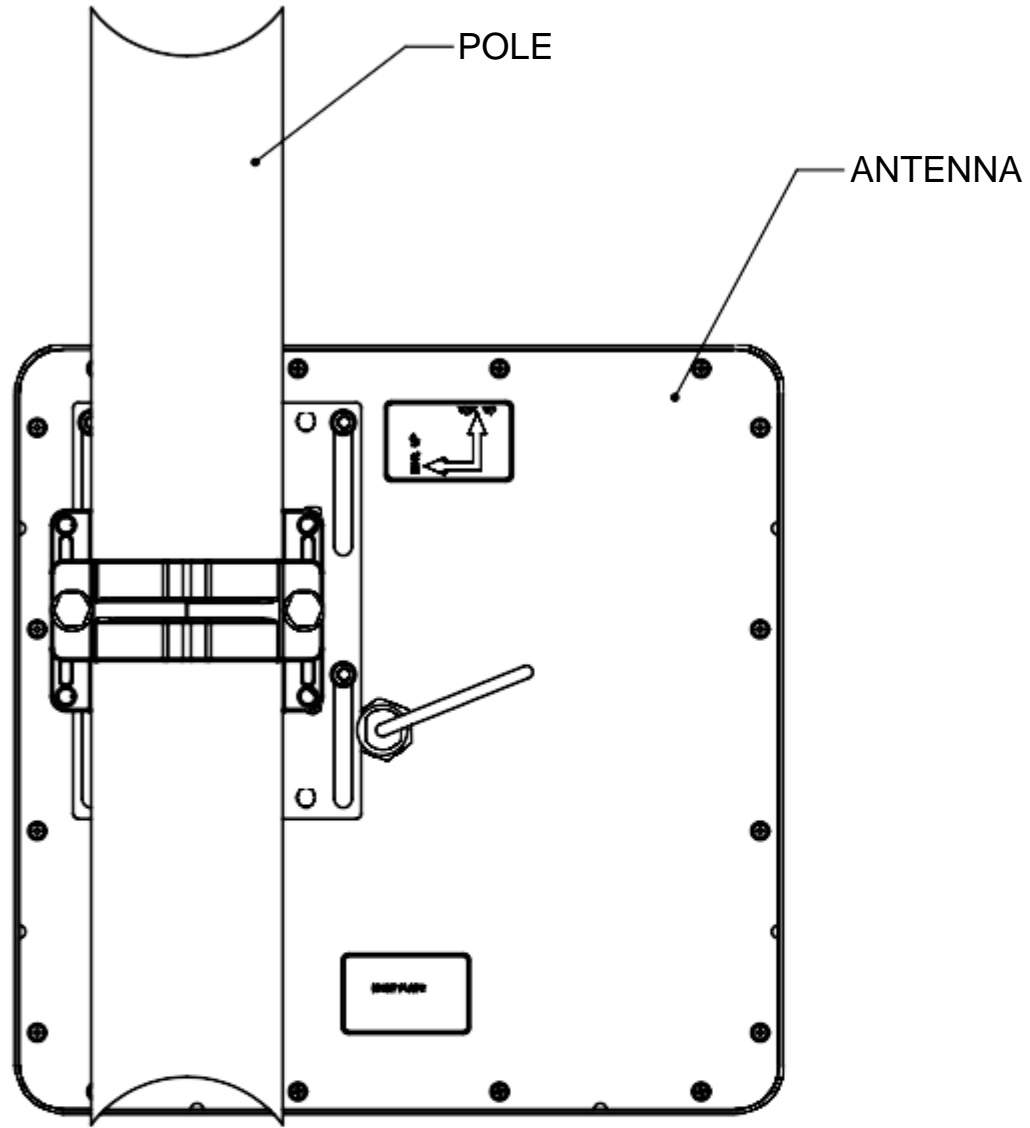

SIZE A3	Rev--	DWG NO RD44507800C	X
SCALE- 1:3		SHEET 2 OF 3	

8 7 6 5 4 3 2 1

8

7

6

5

4

3

2

1

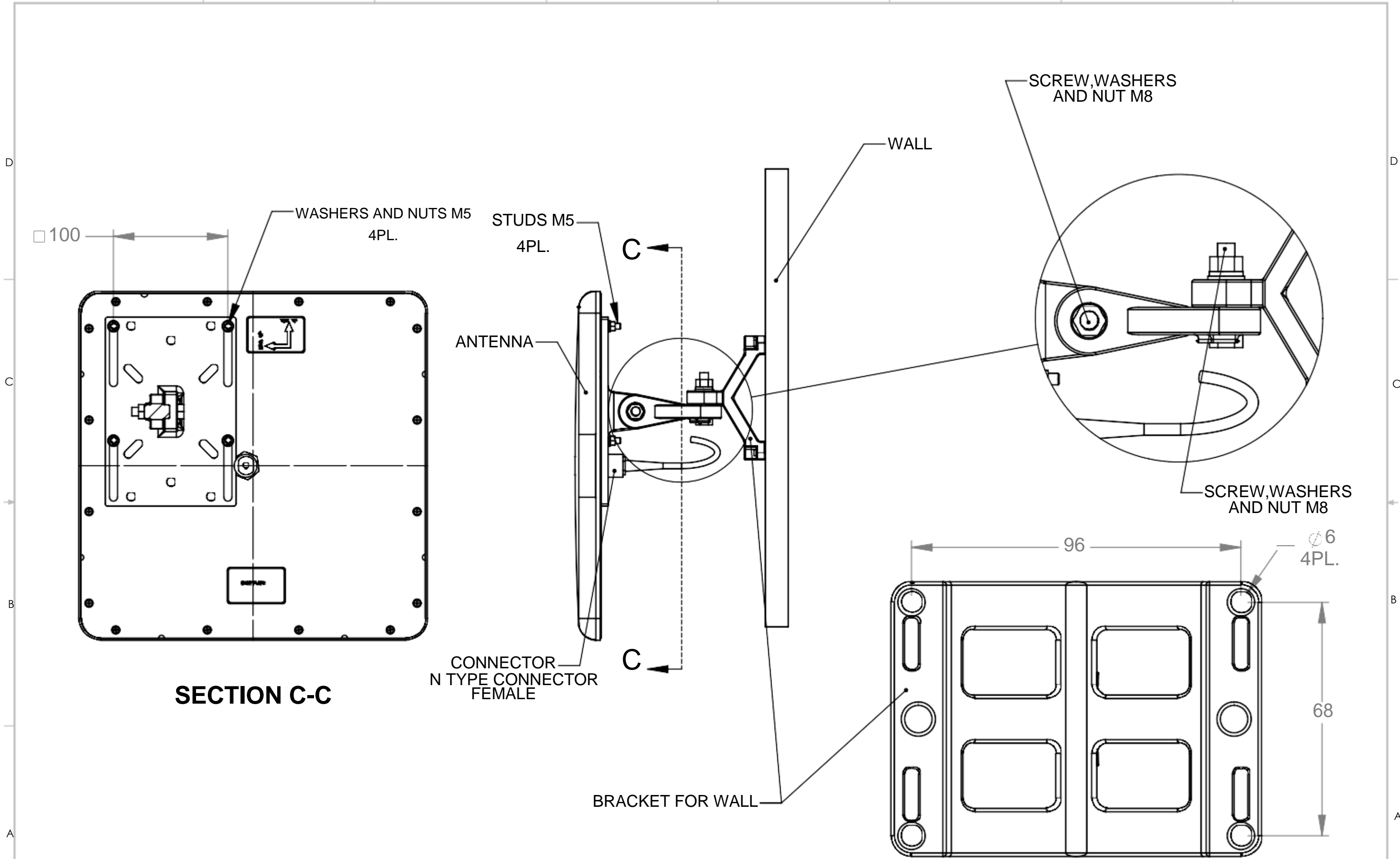

SIZE A3	Rev--	DWG NO RD44507800C
SCALE- 1:3		SHEET 3 OF 3

8

7

6

5

4

3

2

1